



# 300 SERIES

## 615 AT 2525 STD TIPPER 2-WAY GATE



\*Overseas model pictured.  
May contain items not standard to the NZ model.

Euro 5  
Emission Levels

4 x 2 Tipper

### KEY FEATURES

- |   |   |
|---|---|
| ✓ Vehicle Stability Control (VSC)<br>– incl. ABS & TC | ✓ Cruise Control                            |
| ✓ Pre-Collision System (PCS)                          | ✓ SRS Airbag System<br>(Driver & Passenger) |
| ✓ Lane Departure Warning System<br>(LDWS)             | ✓ Reverse Camera                            |
| ✓ ECE-R29 Cab Strength Certified                      |   |

### KEY SPECIFICATIONS

GVM	5,995kg
GCM	8,000kg
Power	150hp
Torque	420Nm
Transmission	6 Speed Automatic
Wheelbase	2.5m
Max Nominal Body Length	3.7m

# HINO 300 SERIES - 615 AT 2525 STD TIPPER 2-WAY GATE

## ENGINE

Model	HINO N04C-WL
Max. Output (ISO NET)	110kW (150 PS) at 2,500 r/min (ISO NET)
Max. Torque (ISO NET)	420Nm (42.9 kgfm) at 1,400–2,500 r/min (ISO NET)
Max. Engine RPM	3,100 RPM
Engine Compliance	ADR 80/03 using Euro 5 Standard
Type	Diesel, turbocharged and intercooled, 4-cycle, in-line 4-cylinder, overhead valve, water-cooled
Combustion System	Compression ignition, four stroke
Bore & Stroke	104 x 118mm
Piston Displacement	4.009L
Compression Ratio	18.0:1
Fuel Injection	Electronic control common rail
Exhaust	Short tail type
Engine Immobiliser	Equipped

## POWER & TORQUE CHART (ISO NET) N04C-WL

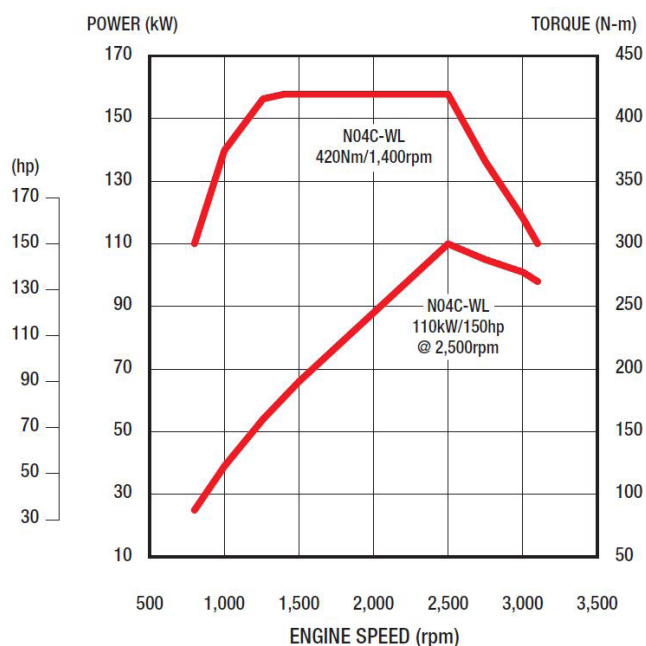

## PERFORMANCE

Calculations based on 5,995kg GVM with 185/85R16 tyres

Engine RPM @ 100km/h	3,100
Max. Theoretical Speed (km/h)	139
Gradeability Tan (%) @ GVM	60

## BRAKES

Type	Dual-circuit hydraulic, vacuum assist
Front Wheel Brake	Disc diameter 296mm, pad effective area 78.4cm <sup>2</sup>
Rear Wheel Brake	Disc diameter 281mm, pad effective area 78.4cm <sup>2</sup>
Vehicle Stability Control (VSC)	Equipped
Pre-Collision System (PCS)	Equipped
Anti-Lock Brake System (ABS)	Equipped (with power assist brake)
Traction Control (TC)	Equipped
Park Brake	Mechanical, internal expanding acting on transmission output shaft, non-folding lever
Exhaust Brake	Equipped

## FUEL TANK

Fuel Capacity	80L
Lockable Fuel Cap	Equipped
Fuel Filter	Primary (with water separator) and secondary filter
Fuel Filler	Small-diameter neck

## TRANSMISSION & GEAR RATIOS

Make & Description	A860E Automatic 6 Speed with Overdrive	
Type	Automatic with Overdrive	
Gear Ratios	1	3.742
	2	2.003
	3	1.343
	4	1.000
	5	0.773
	6	0.634
	Reverse	3.539
Rear Axle Ratio	4.625	

## INSTRUMENTATION

✓ Speedometer	✓ Time
✓ Odometer	✓ Date & Day
✓ Tachometer	✓ Cruise Control
✓ Temperature Gauge	✓ Eco Tree
✓ Fuel Gauge	✓ Display Setting
✓ LCD Display	✓ Safe Driving Settings
✓ Multi Information Display (MID)	✓ System Check
✓ General Information	✓ Steering Wheel Controls
✓ Hour Meter	

# HINO 300 SERIES - 615 AT 2525 STD TIPPER 2-WAY GATE

## SAFETY FEATURES

Active Safety Features	
Vehicle Stability Control (VSC)	Equipped
Anti-Lock Brake System (ABS)	Equipped
Pre-Collision System (PCS)	Equipped
PCS is inclusive of	Safety Eye (SE) Autonomous Emergency Braking (AEB) Pedestrian Detection (PD)
Traction Control (TC)	Equipped
Lane Departure Warning System (LDWS)	Equipped
Reverse Camera (RC)	Equipped
Passive Safety Features	
SRS Airbag for Driver & Passenger	Equipped
SRS Seat Belt Pretensioner for Driver & Passenger	Equipped
Front Underrun Protection Device (FUPD)	Equipped
ECE-R29 Cab Strength Certified	Equipped
LED Day Running Lights	Equipped

## SUSPENSION & LOAD LIMITS

Front	Front Axle Type	Independent Front Suspension (IFS)
	Suspension Description	Double wishbone, independent coil springs with double acting shock absorbers
	Axle Limit (incl. Suspension)	2,400kg
	Tyre Limit	2,180kg
Rear	Rear Axle Model	SH12
	Rear Axle Type	Fully floating, single reduction, single speed by hypoid gearing
	Rear Suspension Type	Leaf spring
	Suspension Description	Semi-elliptic main and auxiliary tapered leaf springs with double acting shock absorbers
	Axle Limit (incl. Suspension)	4,400kg
	Tyre Limit	4,120kg

## STEERING

Type	Telescopic and tilt steering column with locking device, recirculating ball with integral power steering
Steering Angle – Inside	39°
Steering Angle – Outside	29°

## ELECTRICAL

Type	24V negative earth
Batteries	2 x 12V 65Ah 80D26L
Alternator Capacity	24V x 80A
Headlamps & DRL's	LED type

## WHEELS & TYRES

Wheel Type	16 x 5.5 steel wheel 5 stud
Rim Size	16 x 5.5
Tyre Size	185/85R16 111/109
Number of Tyres	7 incl. spare
Spare Tyre Carrier	Equipped

## CHASSIS FRAME

Chassis Frame Wheelbase Variants	XZU655R 3,375mm
Main Section (depth x flange x thickness)	177.8 x 60 x 4.9mm
Chassis Width	700mm
Tensile Strength	540 N/mm <sup>2</sup>
Front Underrun Protection Device (FUPD)	Equipped
Tow Hook Capacity (Front & Rear)	Equipped
Type	Ladder-shaped channel section side rails

## CAB DETAILS

Type	Forward control, all steel welded construction, high roof, mechanical tilt with torsion assist
Driver's Seat	4-way adjustable driver's seat
Seating Capacity	3
SRS Airbag System	Equipped (driver and passenger)
Seat Cover	Fabric type
Floor Covering	Vinyl type
Power Windows	Equipped
Air Conditioner	Equipped
Central Locking & Keyless Entry	Equipped
Rear View Mirrors	Equipped (electric and heated, 2 flat type, 2 convex spotters and kerb view)
Cab Storage Pockets	Equipped on both side doors
Reading Lamp	Equipped
Multimedia System	6.5" LCD, HD touch screen display with DAB+ AM/FM radio, AUX input, Bluetooth® 4.1, Android 6.0, CAN bus connected, and Wi-Fi enabled
LCD Driver Instrument Panel	Equipped

# HINO 300 SERIES - 615 AT 2525 STD TIPPER 2-WAY GATE

## DIMENSIONS

Model	XZU605R-WKTMSQ3D
Product Code	615 AT 2525 STD TIPPER SPLIT TAILGATE MY20
Wheelbase (WB)	2,525
Overall Length (OL)	4,770
Overall Width (OW)	1,880
Overall Height (OH)	2,100
Inside Body Length (IBL)	3,000
Inside Body Width (IBW)	1,750
Inside Body Height (IBH)	370
Front Overhang (FOH)	980
Rear Overhang (ROH)	1,265
Front Chassis Height (FCH)	660
Rear Chassis Height (RCH)	690
Road Clearance (RC)	170
Front Track (FT)	1,400
Rear Track (RT)	1,435
<b>Indicative Chassis Mass (kg) – with 10L of fuel, standard tools, spare tyre, and subject to a ±3% tolerance</b>	
Total	2,800
Front	1,480
Rear	1,320
GVM	5,995
GCM	8,000

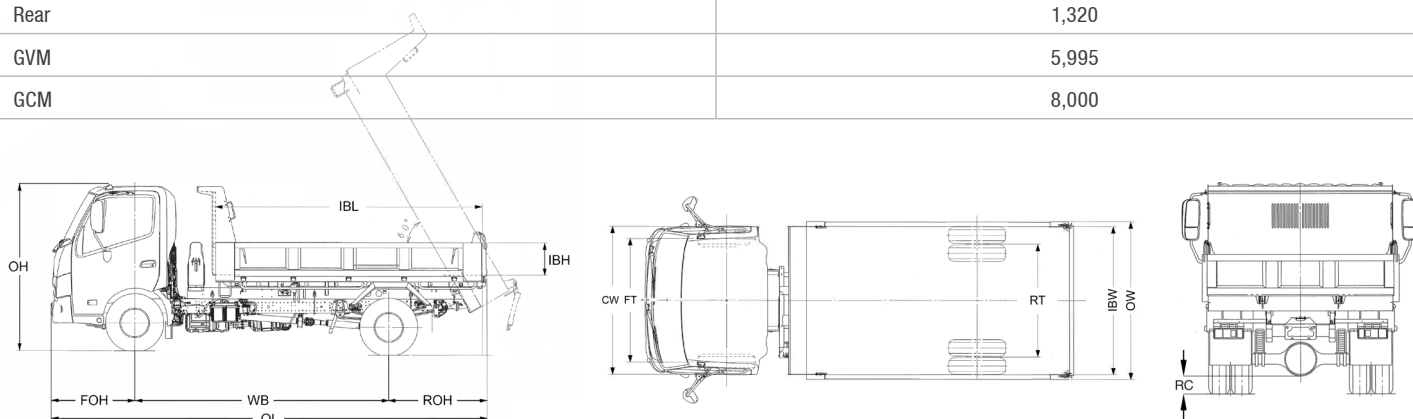

Drawings are for reference only to the table. For specific chassis layouts and dimensions, please refer to Body Mounting Manual drawings.

## WARRANTY

Standard Warranty	Engine & Powerlines
36 months or 100,000kms (whichever comes first)	36 months or 100,000kms (whichever comes first)

## DISCLAIMER

Hino Trucks are distributed in New Zealand by Hino Distributors (NZ) Ltd.

All efforts have been made to ensure the information contained in this brochure was correct at time of printing or uploading. Hino Distributors (NZ) Ltd reserves the right to alter any details of the specifications and equipment without notice. Hino in so far as it is permitted by law to do so, shall not be liable in any way as a result of any reliance placed by any person on anything contained in this brochure. You should therefore check with your authorised Hino dealer at the time of ordering your motor vehicle to ensure that colour, specifications, equipment, design features and options are available for the vehicle you are ordering. Please note that some options may only be available in combination with others. Authorised Hino dealers will on request provide up to date information on all accessories, design features, prices and availability.