

No. CH-11

Unit : mm

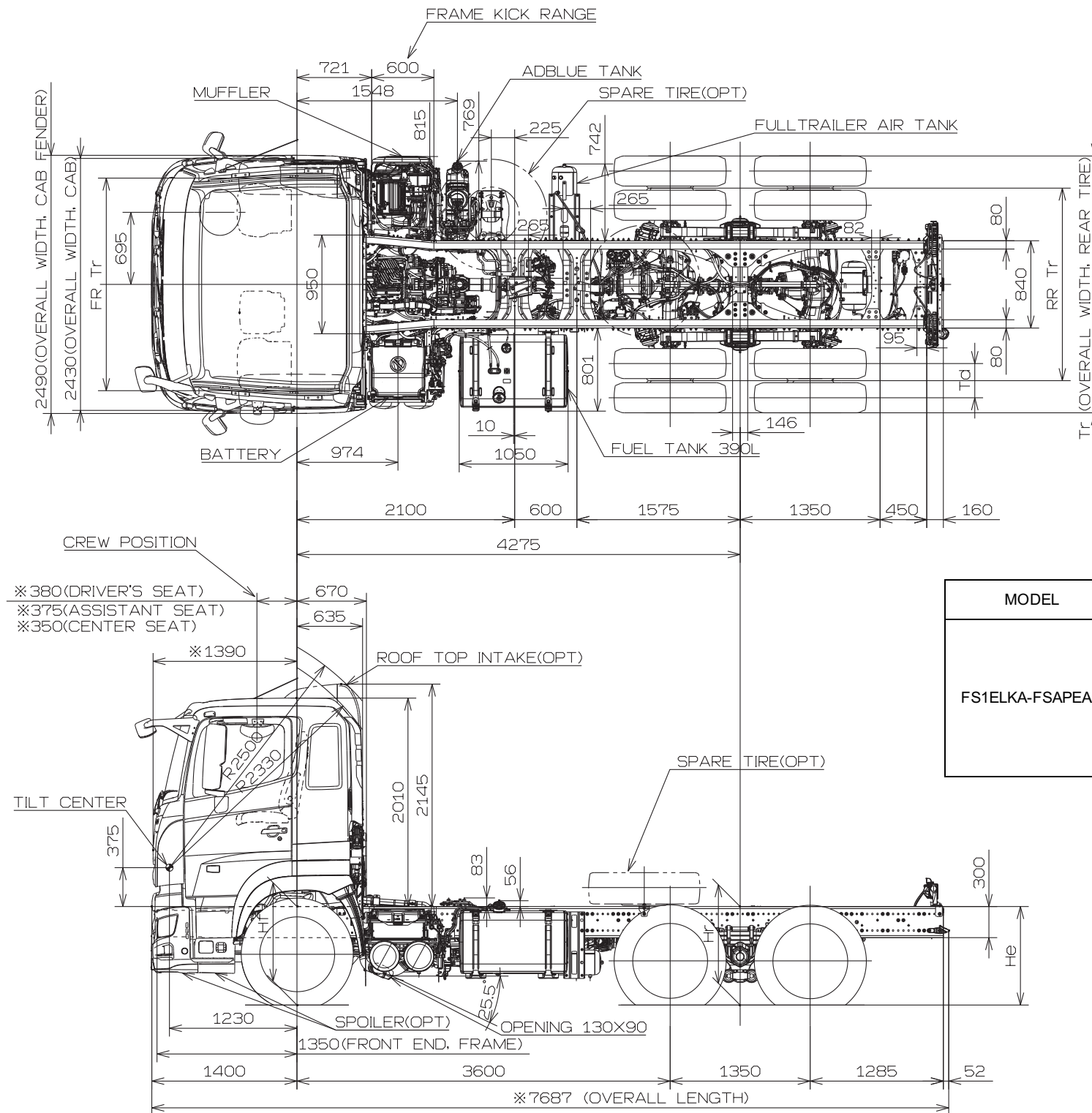

MODEL	TIRE SIZE	DISC SIZE	DIMENSIONS(mm)								
			Hf	Hr	He	A	B	FR Tr	RR Tr	Td	Tr
FS1ELKA-FSAPEAC	F 295/80R22.5,R 11R22.5	F&R 22.5X8.25	1006	1064	1089.8	265	243	2050	1855	330	2466
	F 295/80R22.5,R 11R22.5	F&R 22.5X8.25 ALLOY	1006	1064	1089.8	265	243	2070	1875	330	2482
	F&R 11R22.5-148/145	F&R 22.5X8.25	1010	1064	1089.8	269	243	2050	1855	330	2466
	F&R 11R22.5-148/145	F&R 22.5X8.25 ALLOY	1010	1064	1089.8	269	243	2070	1875	330	2482
	F&R 275/70R22.5-148/145	F&R 22.5X8.25	963	1018	1135.8	222	197	2050	1855	330	2463
	F&R 275/70R22.5-148/145	F&R 22.5X8.25 ALLOY	963	1018	1135.8	222	197	2070	1875	330	2479
	F&R 295/80R22.5	F&R 22.5X8.25	1006	1061	1092.8	265	240	2050	1855	330	2477
	F&R 295/80R22.5	F&R 22.5X8.25 ALLOY	1006	1061	1092.8	265	240	2070	1875	330	2493

NOTE:1.Figures marked"*"dimensions are measured in parellel with the surface of the ground.
 2.The dimension of tire to be mentioned in above table shows design figure according to JATMA or ETRTO standard.

No. CH-12

Unit : mm

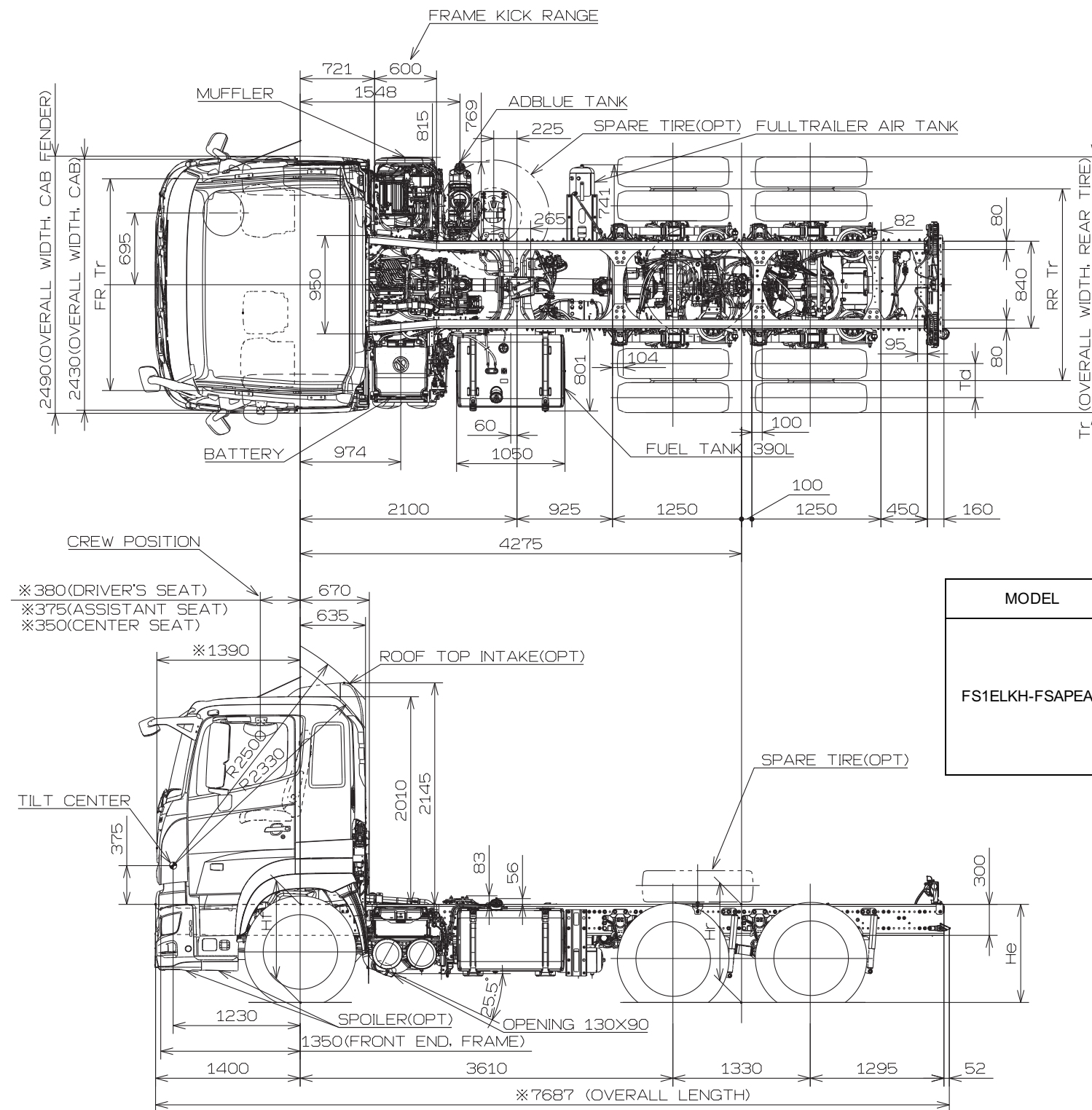

MODEL	TIRE SIZE	DISC SIZE	DIMENSIONS(mm)								
			Hf	Hr	He	A	B	FR Tr	RR Tr	Td	Tr
FS1ELKH-FSAPEAC	F 295/80R22.5,R 11R22.5	F&R 22.5X8.25	1006	1055	1077.2	265	242	2050	1855	330	2466
	F 295/80R22.5,R 11R22.5	F&R 22.5X8.25 ALLOY	1006	1055	1077.2	265	242	2070	1875	330	2482
	F&R 11R22.5-148/145	F&R 22.5X8.25	1010	1055	1077.2	269	242	2050	1855	330	2466
	F&R 11R22.5-148/145	F&R 22.5X8.25 ALLOY	1010	1055	1077.2	269	242	2070	1875	330	2482
	F&R 275/70R22.5-148/145	F&R 22.5X8.25	963	1009	1123.2	222	196	2050	1855	330	2463
	F&R 275/70R22.5-148/145	F&R 22.5X8.25 ALLOY	963	1009	1123.2	222	196	2070	1875	330	2479
	F&R 295/80R22.5	F&R 22.5X8.25	1006	1051	1081.2	265	239	2050	1855	330	2477
	F&R 295/80R22.5	F&R 22.5X8.25 ALLOY	1006	1051	1081.2	265	239	2070	1875	330	2493

NOTE:1.Figures marked"*"dimensions are measured in parellel with the surface of the ground.
 2.The dimension of tire to be mentioned in above table shows design figure according to JATMA or ETRTO standard.

No. CH-13

Unit : mm

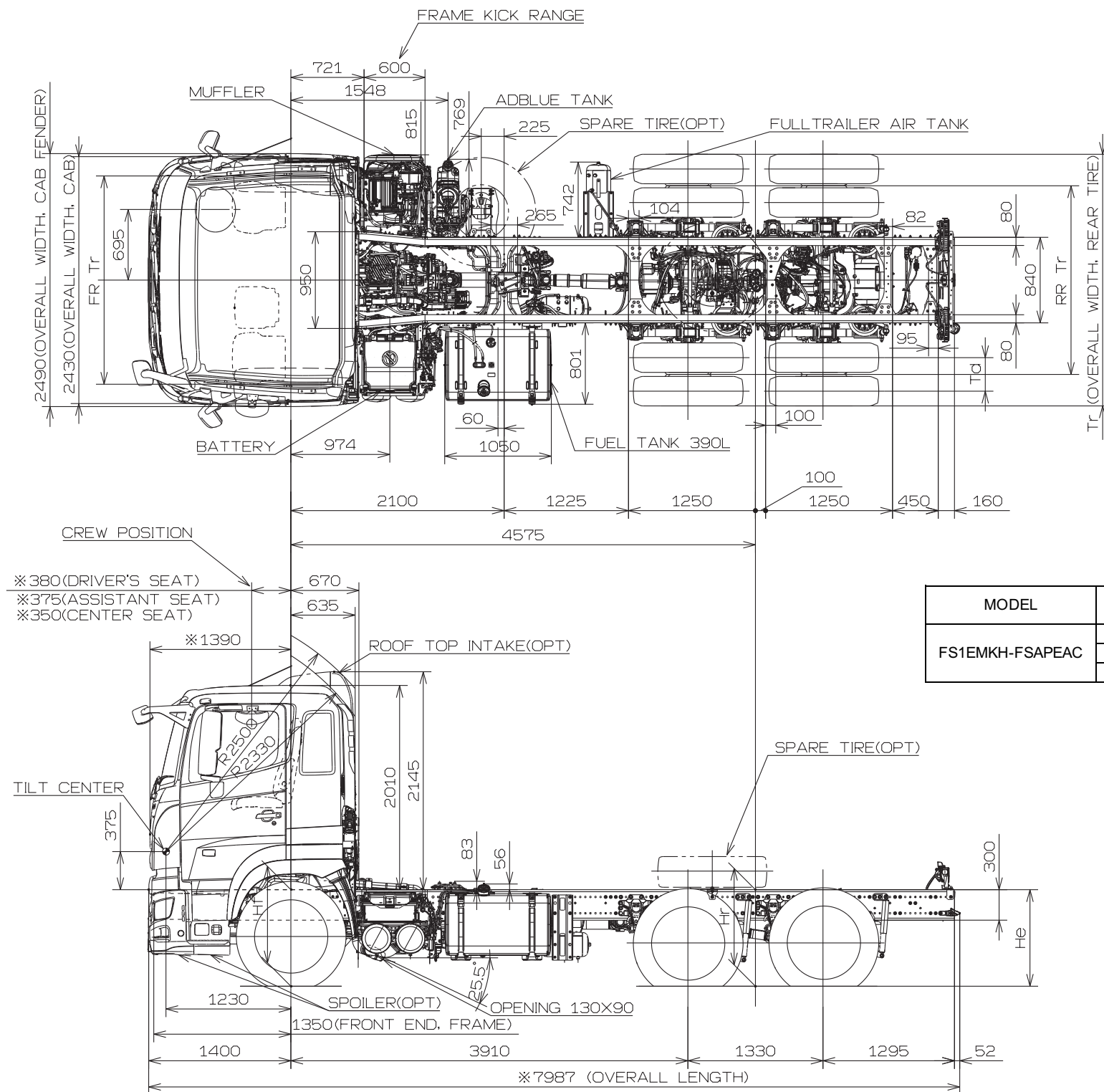

MODEL	TIRE SIZE	DISC SIZE	DIMENSIONS(mm)									
			Hf	Hr	He	A	B	FR Tr	RR Tr	Td	Tr	
FS1EMKH-FSAPEAC	F 295/80R22.5,R 11R22.5	F&R 22.5X8.25	1005	1055	1076.1	265	242	2050	1855	330	2466	
	F 295/80R22.5,R 11R22.5	F&R 22.5X8.25 ALLOY	1005	1055	1076.1	265	242	2070	1875	330	2482	
	F&R 295/80R22.5	F&R 22.5X8.25	1005	1052	1079.1	265	239	2050	1855	330	2477	

NOTE:1.Figures marked "*"dimensions are measured in parallel with the surface of the ground.
 2.The dimension of tire to be mentioned in above table shows design figure according to JATMA or ETRTO standard.