



300 SERIES

917 MT 4200 CREW TIPPER



*Overseas model pictured.
May contain items not standard to the NZ model.

Euro 5
Emission Levels

4 x 2 Tipper

KEY FEATURES

- | | |
|---|---|
| ✓ Vehicle Stability Control (VSC)
– incl. ABS & TC | ✓ SRS Airbag System
(Driver & Passenger) |
| ✓ Pre-Collision System (PCS) | ✓ Reverse Camera |
| ✓ Lane Departure Warning System
(LDWS) | ✓ ECE-R29 Cab Strength Certified |
| ✓ Cruise Control | ✓ ES Start (Hill Start System) |

KEY SPECIFICATIONS

GVM	8,500 or 5,995kg
GCM	12,000kg
Power	165hp
Torque	464Nm
Transmission	6 Speed Manual
Wheelbase	4.2m
Max Nominal Body Length	5.4m

ENGINE

Model	HINO N04C-WM
Max. Output (ISO NET)	121kW (165 PS) at 2,500 r/min (ISO NET)
Max. Torque (ISO NET)	464Nm (47.3 kgfm) at 1,400–2,500 r/min (ISO NET)
Max. Engine RPM	3,100 RPM
Engine Compliance	ADR 80/03 using Euro 5 Standard
Type	Diesel, turbocharged and intercooled, 4-cycle, in-line 4-cylinder, overhead valve, water-cooled
Combustion System	Compression ignition, four stroke
Bore & Stroke	104 x 118mm
Piston Displacement	4.009L
Compression Ratio	18.0:1
Fuel Injection	Electronic control common rail
Exhaust	Short tail type
Engine Immobiliser	Equipped

POWER & TORQUE CHART (ISO NET) N04C-WM

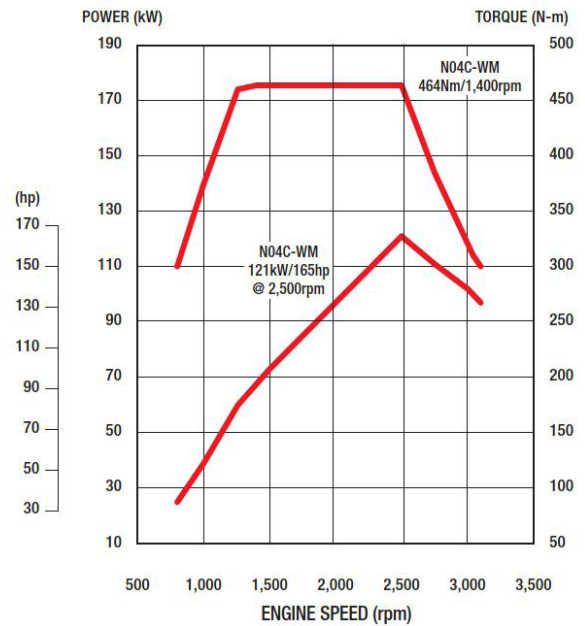

PERFORMANCE

Calculations based on 8,500kg GVM with 225/80R17.5 tyres

Engine RPM @ 126km/h	3,100
Max. Theoretical Speed (km/h)	126
Gradeability Tan (%) @ GVM	47.1

BRAKES

Type	Dual-circuit hydraulic, vacuum assist
Front Wheel Brake	Disc diameter 287mm, pad effective area 84cm ²
Rear Wheel Brake	Disc diameter 287mm, pad effective area 84cm ²
Vehicle Stability Control (VSC)	Equipped
Pre-Collision System (PCS)	Equipped
Anti-Lock Brake System (ABS)	Equipped (with power assist brake)
Traction Control (TC)	Equipped
Easy Start Hill Assist (ES)	Equipped
Park Brake	Mechanical, internal expanding acting on transmission output shaft, non-folding lever
Exhaust Brake	Equipped

FUEL TANK

Fuel Capacity	100L
Lockable Fuel Cap	Equipped
Fuel Filter	Primary (with water separator) and secondary filter
Fuel Filler	Small-diameter neck

TRANSMISSION & GEAR RATIOS

Make & Description	Hino RE61 Manual 6 Speed	
Type	Manual	
Gear Ratios	1	6.370
	2	3.870
	3	1.913
	4	1.461
	5	1.000
	6	0.703
	Reverse	5.926
Rear Axle Ratio	5.142	

CLUTCH

Type	Dry single plate with damper springs, facing outside diameter 325mm, automatic gap adjuster
Control	Hydraulic with air booster

INSTRUMENTATION

✓ Speedometer	✓ Time
✓ Odometer	✓ Date & Day
✓ Tachometer	✓ Cruise Control
✓ Temperature Gauge	✓ Eco Tree
✓ Fuel Gauge	✓ Display Setting
✓ LCD Display	✓ Safe Driving Settings
✓ Multi Information Display (MID)	✓ System Check
✓ General Information	✓ Steering Wheel Controls
✓ Hour Meter	

SAFETY FEATURES

Active Safety Features	
Vehicle Stability Control (VSC)	Equipped
Anti-Lock Brake System (ABS)	Equipped
Pre-Collision System (PCS)	Equipped
PCS is inclusive of	Safety Eye (SE) Autonomous Emergency Braking (AEB) Pedestrian Detection (PD)
Traction Control (TC)	Equipped
Lane Departure Warning System (LDWS)	Equipped
Reverse Camera (RC)	Equipped
Easy Start Hill Assist (ES)	Equipped
Passive Safety Features	
SRS Airbag for Driver & Passenger	Equipped
SRS Seat Belt Pretensioner for Driver & Passenger	Equipped
Front Underrun Protection Device (FUPD)	Equipped
ECE-R29 Cab Strength Certified	Equipped
LED Day Running Lights	Equipped

SUSPENSION & LOAD LIMITS

Front	Front Axle Type	Reversed Elliot I Section Beam
	Suspension Description	Semi-elliptic main and auxillary tapered leaf springs with double acting shock absorbers
	Axle Limit (incl. Suspension)	3,100kg
	Tyre Limit	3,100kg
Rear	Rear Axle Model	SH13
	Rear Axle Type	Fully floating, single reduction, single speed by hypoid gearing
	Rear Suspension Type	Leaf spring
	Suspension Description	Semi-elliptic main and auxillary tapered leaf springs with double acting shock absorbers
	Axle Limit (incl. Suspension)	6,200kg
	Tyre Limit	6,000kg

STEERING

Type	Telescopic and tilt steering column with locking device, recirculating ball with integral power steering
Steering Angle – Inside	44°
Steering Angle – Outside	34°

ELECTRICAL

Type	24V negative earth
Batteries	2 x 12V 65Ah 80D26L
Alternator Capacity	24V x 80A
Headlamps & DRL's	LED type

WHEELS & TYRES

Wheel Type	17.5 x 6.0 steel wheel 6 stud
Rim Size	17.5 x 6.0
Tyre Size	225/80R17.5 123/122
Number of Tyres	7 incl. spare
Spare Tyre Carrier	Equipped

CHASSIS FRAME

Main Section (depth x flange x thickness)	192.8 x 65 x 5.9mm
Chassis Width	750mm
Tensile Strength	540 N/mm ²
Front Underrun Protection Device (FUPD)	Equipped
Tow Hook Capacity (Front & Rear)	Equipped
Type	Ladder-shaped channel section side rails

CAB DETAILS

Type	Forward control, all steel welded construction, high roof, mechanical tilt with torsion assist
Driver's Seat	4-way adjustable driver's seat
Seating Capacity	7
SRS Airbag System	Equipped (driver and passenger)
Seat Cover	Fabric type
Floor Covering	Vinyl type
Power Windows	Equipped
Air Conditioner	Equipped
Central Locking & Keyless Entry	Equipped
Internal & Rear View Mirrors	Equipped
Reading Lamp	Equipped
Multimedia System	6.5" LCD, HD touch screen display with DAB+ AM/FM radio, AUX input, Bluetooth® 4.1, Android 6.0, CAN bus connected, and Wi-Fi enabled
LCD Driver Instrument Panel	Equipped

HINO 300 SERIES - 917 MT 4200 CREW TIPPER

DIMENSIONS

Model	XZU730R-ZKFTTQ3D
Product Code	917 MT 4200 WIDE CREW TIPPER MY20
Wheelbase (WB)	4,200
Overall Length (OL)	7,200
Overall Width (OW)	2,200
Overall Height (OH)	2,260
Inside Body Length (IBL)	4,000
Inside Body Width (IBW)	2,000
Inside Body Height (IBH)	430
Front Overhang (FOH)	1,125
Rear Overhang (ROH)	1,875
Front Chassis Height (FCH)	725
Rear Chassis Height (RCH)	810
Road Clearance (RC)	200
Front Track (FT)	1,655
Rear Track (RT)	1,590
Indicative Chassis Mass (kg) – with 10L of fuel, standard tools, spare tyre, and subject to a ±3% tolerance	
Total	4,035
Front	1,995
Rear	2,040
GVM	8,500 or 5,995
GCM	12,000

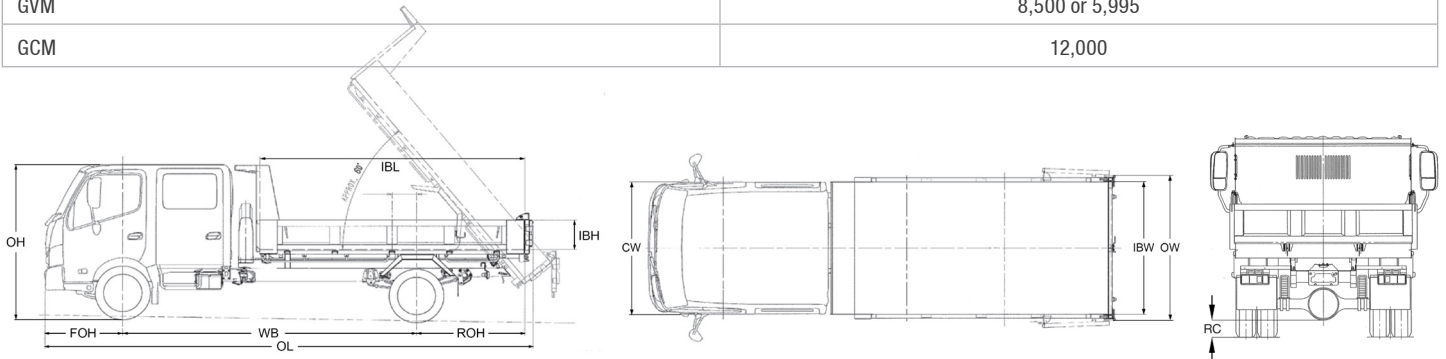

Drawings are for reference only to the table. For specific chassis layouts and dimensions, please refer to Body Mounting Manual drawings.

WARRANTY

Standard Warranty	Engine & Powerlines
36 months or 100,000kms (whichever comes first)	36 months or 100,000kms (whichever comes first)

DISCLAIMER

Hino Trucks are distributed in New Zealand by Hino Distributors (NZ) Ltd.

All efforts have been made to ensure the information contained in this brochure was correct at time of printing or uploading. Hino Distributors (NZ) Ltd reserves the right to alter any details of the specifications and equipment without notice. Hino in so far as it is permitted by law to do so, shall not be liable in any way as a result of any reliance placed by any person on anything contained in this brochure. You should therefore check with your authorised Hino dealer at the time of ordering your motor vehicle to ensure that colour, specifications, equipment, design features and options are available for the vehicle you are ordering. Please note that some options may only be available in combination with others. Authorised Hino dealers will on request provide up to date information on all accessories, design features, prices and availability.