



500 SERIES

FC 1124 MT SPRING 3850 TIPPER



*Overseas model pictured.
May contain items not standard to the NZ model.

pPNLT Emission Levels
(Euro 6 Equivalent)

4 x 2 Tipper

KEY FEATURES

- | | |
|---|--|
| ✓ Vehicle Stability Control (VSC)
– incl. ABS & TC | ✓ Euro 6 Equivalent Emissions |
| ✓ Pre-Collision System (PCS) | ✓ Lane Departure Warning System (LDWS) |
| ✓ SRS Airbag System (Driver) | ✓ ECE-R29 Cab Strength Certified |
| ✓ Engine Retarder Brake (Jake Brake) | ✓ Adaptive Cruise Control (ACC) |

KEY SPECIFICATIONS

GVM	11,000kg
GCM	20,000kg
Power	240hp / 177kW
Torque	794Nm
Transmission	6 Speed Manual
Wheelbases	3.9m
Tipper Body Length	4.0m

HINO 500 SERIES - FC 1124 MT SPRING 3850 TIPPER

ENGINE

Model	HINO A05C-TE
Max. Output (ISO NET)	240hp / 177kW @ 2,300 RPM
Max. Torque (ISO NET)	794Nm @ 1,400 RPM
Max. Engine RPM	2,550 RPM
Engine Compliance	ADR 80/03 using Japan pPNLT (Euro 6 Equivalent Emissions)
Type	Diesel, turbocharged and intercooled 4 cylinder with overhead camshaft
Combustion System	Direct injection with EGR
Bore & Stroke	112 x 130mm
Piston Displacement	5.123L
Compression Ratio	17.5:1
Fuel Injection	Electronic control common rail
Air Compressor / Bore & Stroke	Single cylinder / 70 x 40mm
Air Cleaner	Dual paper elements
Exhaust	Horizontal outlet RHS
Emission Control System	DPR & SCR (AdBlue®)
Engine Immobiliser	Equipped

PERFORMANCE

Calculations based on 11,000kg GVM with 235/75R17.5 tyres

Engine RPM @ 100km/h	2,374
Max. Theoretical Speed (km/h)	108
Gradeability Tan (%) @ GVM	55.8

BRAKES

Type	Drum brakes front and rear	
Control	Air Over Hydraulic (AOH), dual circuit with ABS	
Drum Diameter x Lining Width	Front	320 x 110mm
	Rear	320 x 120mm
Air Dryer	Equipped	
Vehicle Stability Control (VSC)	Equipped	
Pre-Collision System (PCS)	Equipped	
Anti-Lock Brake System (ABS)	Equipped	
Traction Control (TC)	Equipped	
Easy Start Hill Assist (ES)	Equipped	
Park Brake	Spring brake acting on rear wheels	
Exhaust & Engine Brake (Jake Brake)	Equipped	
Brake Lock	Equipped	

STEERING

Type	Telescopic and tilt steering column with locking device, recirculating ball with integral power steering
Gear Ratio	19.0:1
Steering Angles	53° Inside, 38° Outside

POWER & TORQUE CHART (ISO NET) A05C-TE

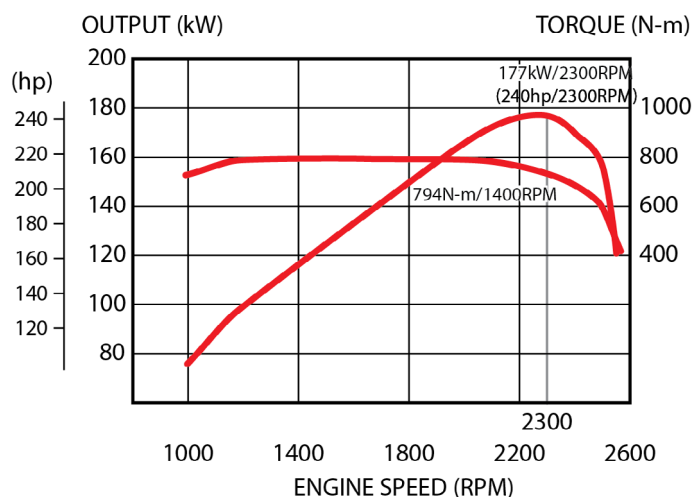

TRANSMISSION & GEAR RATIOS

Make & Description	Hino LX06S, 6 Speed Synchromesh with Cable Shift & Air Assist	
Type	Manual with Overdrive	
Gear Ratios	1	6.098
	2	3.858
	3	2.340
	4	1.422
	5	1.000
	6	0.744
	Reverse	5.672
Rear Axle Ratio	4.625	
PTO Option / Torque Capacity	Single / 245Nm	

CLUTCH

Model	CSP-350
Type	Dry single plate
Clutch Plate	350mm Organic
Control	Hydraulic with air booster

FUEL TANK

Material	Steel
Fuel Capacity	200L
Lockable Fuel Cap	Equipped
Prefilter & Sedimenter	Equipped
AdBlue® Capacity	19L

HINO 500 SERIES - FC 1124 MT SPRING 3850 TIPPER

SAFETY FEATURES

Active Safety Features	
Vehicle Stability Control (VSC)	Equipped
Anti-Lock Brake System (ABS)	Equipped
Pre-Collision System (PCS)	Equipped
PCS is inclusive of	Safety Eye (SE) Autonomous Emergency Braking (AEB) Pedestrian Detection (PD)
Traction Control (TC)	Equipped
Lane Departure Warning System (LDWS)	Equipped
Staggering Warning (SW)	Equipped
Adaptive Cruise Control (ACC)	Equipped
Reverse Camera (RC)	Equipped
Easy Start Hill Assist (ES)	Equipped
Passive Safety Features	
SRS Airbag	Equipped (for driver)
SRS Seat Belt Pretensioner	Equipped (for driver)
Front Underrun Protection Device (FUPD)	Equipped
ECE-R29 Cab Strength Certified	Equipped

SUSPENSION & LOAD LIMITS

Front	Front Axle Model	LF 456	
	Front Axle Type	I-Beam, Reverse Elliot	
	Front Suspension Type	Taper leaf springs with shock absorbers and stabiliser	
	Spring Dimensions	1,300 x 70mm	
	Spring Rate (kgf/mm ²)	23.0	
	Axle Limit (incl. Suspension)	4,100kg	
	Tyre Limit	4,000kg	
Rear	Rear Axle Model	SH13	
	Rear Axle Type	Fully floating, single reduction by hypoid gears	
	Rear Suspension Type	Taper leaf main and auxiliary with shock absorbers	
	Suspension Dimensions	Main	Auxiliary
		Length x Width (mm)	1,300 x 70mm
	Number	8	9
	Spring Rate (kgf/mm ²)	25	74
	Axle Limit (incl. Suspension)	7,000kg	
Tyre Limit	7,600kg		

ELECTRICAL

Type	24V negative earth
Batteries	2 x 12V 120Ah (115F51)
Alternator Capacity	24V x 90A
Starter Type	24V x 4.5kW
Headlamps	LED main beam with LED daytime running lamps
LED Interior & Reading Lamp	Equipped
Electric Air Horn	Equipped

CAB DETAILS

Type	Forward control, day cab, all steel construction with torsion bar tilt mechanism
Grille Colour	Matte grey
Seating Capacity	3
Driver's Seat	ISRI 6860 NTS2 air suspension, 10 way adjustable with integrated safety belt and rear pocket
Side Passenger Seat	High back and reclining seat
Centre Seat	Foldaway type with integrated tray
Seat Belts	3 point lap sash for driver and side passenger, 2 point lap for centre position
Sunvisor & Overhead Console	Equipped (for driver and side passenger)
Windscreen Wipers	2 arm wiper and washers, 2 speed with intermittent
Cab Heater & Air Conditioner	Equipped with 4 speed fan
Auxiliary Power Supply	12V x 120W socket and USB 2.1A
Rear-View Mirrors	External: Electric and heated, 2 flat type, 2 convex spotters and kerb view
Floor Covering	Vinyl type
Central Locking & Keyless Entry	Equipped with immobiliser
Cab Storage Pockets	Equipped in both side doors
Power Windows	Equipped
Foot Rest	Equipped
Cup Holders	3 centre and 2 door beverage holders
Multimedia System	6.5" LCD, HD touch screen display with DAB+ AM/FM radio, AUX input, Bluetooth® 4.1, Android 6.0, CAN bus connected, and Wi-Fi enabled

INSTRUMENTATION

Meters	Steering Wheel Controls
✓ Speedometer	✓ Cruise Control
✓ Tachometer	✓ MID Control
✓ Air Gauges	✓ Window Wiper Controls
LCD Display	Additional Switches & Controls
✓ Time	✓ External Flat Mirror Control
✓ Temperature Gauge	✓ VSC Off
✓ AdBlue® Gauge	✓ PCS Off
✓ Fuel Gauge	✓ LDWS Off
✓ Odometer	✓ Idle Up
✓ Hour Meter	✓ Quick Warm Up
✓ Date & Day	✓ ES Control
Multi Information Display (MID)	✓ ECO Run
✓ General Information	✓ Mirror Heater
✓ Cruise Control	✓ Engine Brake
✓ Eco Tree	✓ DPR Regeneration
✓ Display Setting	✓ Electric Window Lock Out
✓ Safe Driving Settings	✓ Headlight Leveller
✓ System Check	✓ Tipper Control Lever

HINO 500 SERIES - FC 1124 MT SPRING 3850 TIPPER

WHEELS & TYRES

Wheel Type	6 stud disc wheel (JIS type) PCD 222.25
Rim Size	6.75" x 17.5" / 135mm offset (alloy)
Tyre Size	235/75R15.5 132/130
Number of Tyres	7 incl. spare
Spare Tyre Carrier	Equipped

DIMENSIONS (MM)

Model	FC2AG1A-DBAAE TP4.0
Product Code	FC 1124 MT SPRING 3850 Tipper4.0
Suspension	Leaf Spring
Wheelbase (WB)	3,850
Overall Length (OL)	6,445
Overall Width (OW)	2,260
Overall Height (OH)	2,430
Front Overhang (FOH)	1,145
Rear Overhang (ROH)	1,450
Front Track (FT)	1,780
Rear Track (RT)	1,660
Kerb to Kerb	12,400
Wall to Wall	13,800
Inside Body Length (IBL)	4,000
Inside Body Width (IBW)	2,060
Deck Height (DH)	1,175
Cab to Body (CB)	540
Tipper Volume	3.5m ³
Tipping Angle (TA)	55°
Drop Side Height	430
Indicative Chassis Mass (kg) – with 10L of fuel, no tools or spare tyre, and subject to a ±3% tolerance	
Total	4,880
Front	2,660
Rear	2,220
GVM	11,000
GCM	20,000

CHASSIS FRAME

Main Section (depth x flange x thickness)	228.4 x 73 x 5.2mm
Chassis Width	820mm
Tensile Strength	540 N/mm ² (55 kgf/mm ²)
Tow Hook (Front & Rear)	2,000 kgf (max angle of 15°)
Type	Ladder-shaped channel section side rails
Tipper Deck Plate Thickness	6mm
Tipper Side, Front, & Tailgate Thickness	3.2mm

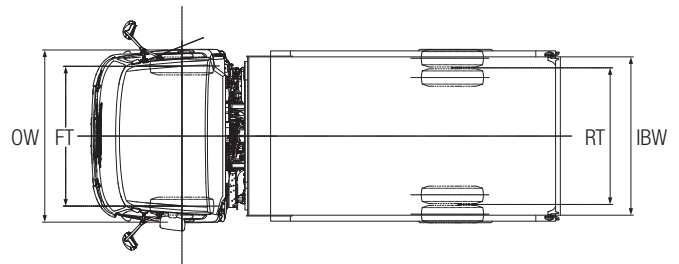
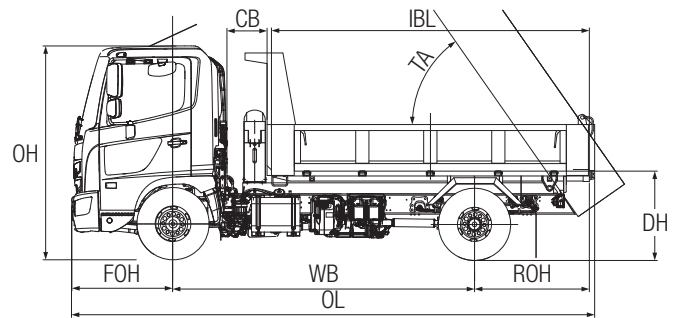

Drawings are for reference only to the table. For specific chassis layouts and dimensions, please refer to Body Mounting Manual drawings.

WARRANTY

Standard Warranty

24 months or 100,000kms
(whichever comes first)

Engine & Powerlines

36 months or 150,000kms
(whichever comes first)

DISCLAIMER

Hino Trucks are distributed in New Zealand by Hino Distributors (NZ) Ltd.

All efforts have been made to ensure the information contained in this brochure was correct at time of printing or uploading. Hino Distributors (NZ) Ltd reserves the right to alter any details of the specifications and equipment without notice. Hino in so far as it is permitted by law to do so, shall not be liable in any way as a result of any reliance placed by any person on anything contained in this brochure. You should therefore check with your authorised Hino dealer at the time of ordering your motor vehicle to ensure that colour, specifications, equipment, design features and options are available for the vehicle you are ordering. Please note that some options may only be available in combination with others. Authorised Hino dealers will on request provide up to date information on all accessories, design features, prices and availability.